



Self-contained ice maker - Granular system
Daily production up to 73 kg

Hotel	████████████████████
Restaurant	████████████████████
Fast food	████████████████████
Bar	████████████████████
Disco	████████████████████
Fish market	████████████████████
Supermarket	████████████████████
Medical & SPA	████████████████████
Industry	████████████████████

► **Position n°**



► **Features & Plus**

- Granular ice - 80-82% dry
- 1l (water) - 1kg (ice) - only Air cooled
- AISI 304 SS Scotch Brite finish
- Tropical class +43°C
- Removable and cleanable air filter
- AISI 304 SS evaporator
- Air or water cooling system
- Easy cleanable internal rounded surfaces
- HCFC-Free insulated storage
- Dust-proof water basin
- RoHS Free
- Disappearing insulated door
- Electromechanical operation
- ON-OFF rocker switch
- Automatic water charge
- Standard and special voltages
- HFC Free



AISI 304 SS Scotch Brite finish



Removable and cleanable air filter



AISI 304 SS evaporator



Dust-proof water basin



Disappearing insulated door

► **Prod. 24h**

Air temp.	Water temp.		Kg	Lbs	
	10° C	50° F			7° C
21° C	70° F	15° C	60° F	67	148



► **Certifications available for this model**





Ice Flakes

FHT60 A/W HC Infrico

Self-contained ice maker - Granular system Daily production up to 73 kg

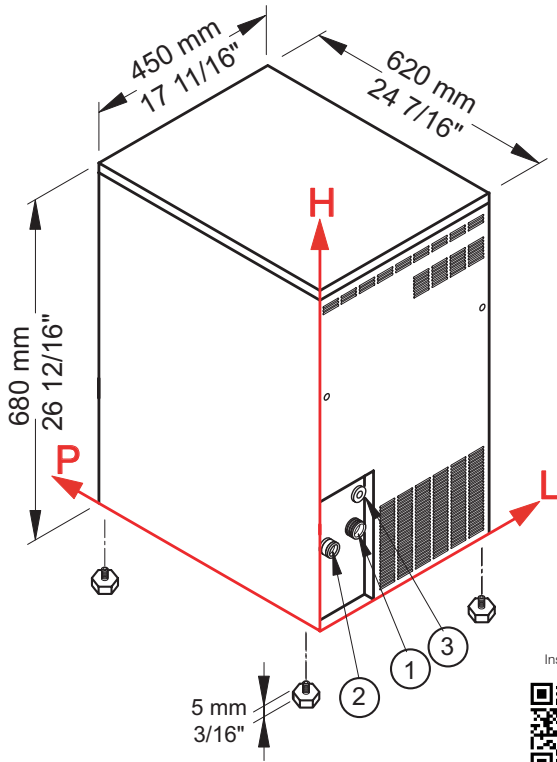

► Working conditions

- Location: **Indoor**

	Min	Max
Ambient temperature	+10° C / +50° F	+43° C / 110° F
Water temperature	+3° C / +37° F	+32° C / +90° F
Voltage	-10%	+10%
Water inlet pressure	1bar (14 psi)	6bar (84 psi)

► Performances

	Air temperature	Water temperature	Water temperature					
			7° C	45° F	15° C	60° F	21° C	70° F
	10° C	73 kg						
	50° F	161 lbs						
	21° C			67 kg				
	70° F			148 lbs				
	32° C					53 kg		
	90° F						117 lbs	

► Connections

All measures are referred to the rear bottom-left corner (L-H-Ø)

- ① Water in.: 106 mm / 4 3/16" - 135 mm / 5 5/16" - 3/4"
- ② Water out.: 55 mm / 2 3/16" - 140 mm / 5 8/16" - 24 mm / 15/16"
- ③ Electrical connections: 114 mm / 4 8/16" - 218 mm / 8 9/16"

► Technical information

Production in 24h	73 kg / 161 lbs
Store capacity, up to	9 kg / 20 lbs
Cooling system	A - W
Refrigerant	R290
Standard voltage	220-240 V ~ 50 Hz
Average power consumption	400 W
Fuse	10 A
Electrical consumption	16 kWh/100kg
Finish	AISI 304 stainless steel, scotch brite

Water consumption	A: 1 l/kg - 12,0 gal/100 lbs
	W: 5 l/kg - 60 gal/100 lbs
Sizes (L-P-H mm)	450 - 620 - 680
(L-P-H in)	17 11/16 - 24 7/16 - 26 12/16
Sizes with pack (L-P-H mm)	505 - 675 - 850
(L-P-H in)	19 14/16 - 26 9/16 - 33 7/16
Net weight	56 kg / 123 lbs
Gross weight	64 kg / 141 lbs

All the technical information must be considered at the following conditions:

- Sizes without feet
- Ambient temperature +21° C
- Water temperature +15° C
- Electrical consumption at +32° C (standard voltage)
- Average power consumption at +43° C (standard voltage)

Models and specifications are subject to change without notice

Rev. 04 - Issued September 2019